

Robotrad Moulding Divider serie



Robotrad-t

Semi automatic moulding divider with interchangeable grill in the lid

Daub's Robotrad-t is a hydraulic divider for artisan bread that benefited from a long pre-proofing time. By using a grill inside the lid, it is possible to divide the dough without the use of any pressure. Dividing is achieved by pushing the dough against the removable grill which is available in various long, square and triangle versions.

As the dough comes out in its final shape, it can be transferred straight into the oven.

The position of the moulding grill inside the lid provides absolute safety for the baker or any other operator. By replacing the grill with a flat top plate, Robotrad-t has all the functionality of the classic Daub Robocut hydraulic dough divider.

The top plate and grill are both Teflon coated for easy cleaning and reducing the need for flour during the dividing process. When not in use, the grill or top plate can be placed in one of the two supports placed on both sides of the machine.



The Robotrad-t is a unique divider for artisan bread that has benefited from a long pre-proofing time. By using a grid the dough comes out in its final shape.

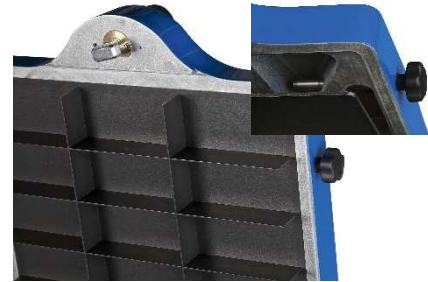

Absolute safety for operator with Teflon coated grill inside the lid.



Holders for grills, press or top plates on both sides of the machine.



A Teflon coated cast-iron dividing disc with stainless steel knife and ring around the dough tub.



Standard on Variomatic and an interesting option on other models; variable pressure regulation.



Robotrad-t

Semi automatic moulding divider with interchangeable grill in the lid

- Interchangeable Teflon coated moulding grill within the lid for maximum safety
- Grills are removed, changed and secured in a few simple natural movements
- Broad range of 22 different interchangeable grilles with various long, square and triangle moulding shapes
- Two grilles supports on both sides of the machine
- Pressing and moulding by joy stick or touch control; with end-time and cycle time reduction
- Teflon coated dividing disc with stainless steel dividing knife
- Removable Teflon coated top-plate to replace grill for classic divider function
- Comes standard with 2 pressing plates

Options

- Double dividing disc 10/20x or 20/40x
- Variable hydraulic pressure regulation
- Transformer for 4 wire connections without N at 400V
- Hygienic glass panel with durable touch controls
- Safety switches on front and removable side panels
- Cast iron foot on wheels for extra stability but still easy movable

Power 1.6 kW, 3-phase, net weight 335 kg
WxDxH 76 x 66 x 108 cm

See also Robocut divider for more informations.

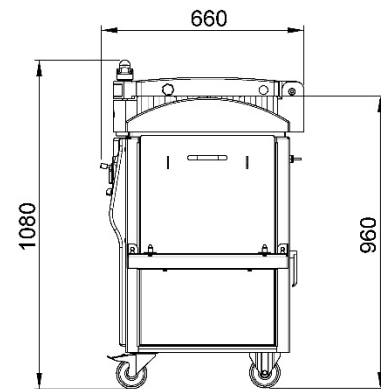
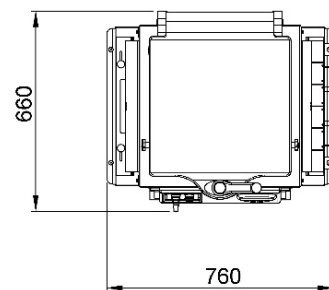
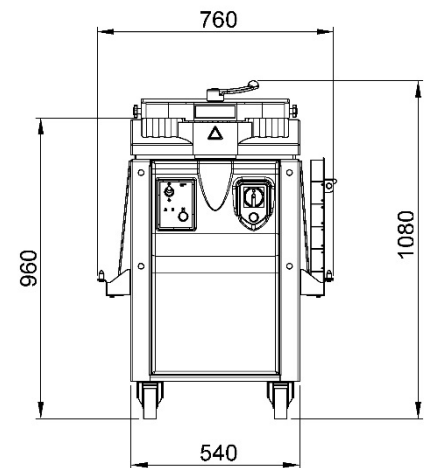

Voltage	Hz	Phase	Ampere	Wattage
400 - 460 V	50 - 60 Hz	3 phase / ground / neutral	6A	1.6 kW
200 - 270 V	50 - 60 Hz	3 phase / ground	9A	1.6 kW
400 - 460 V	50 - 60 Hz	3 phase / ground	6A	1.6 kW
208 V	60 Hz	3 phase / ground	9A	1.6 kW

